



# VOICE COIL LINEAR MOTOR

## VC-7622-T

### INTENDED USE

**Mager** designs high performing voice coil linear motors, **VC series**.

A linear voice coil actuator is ideal for short strokes closed loop servo applications. Its compact size allows it to fit into small spaces. It has very low electrical and mechanical time constants. The low moving mass allows for high accelerations of light payloads. The result is a much simpler and more reliable system.

The strength point is: if the voice coil is equipped with a properly driven drive, it is able to develop a controlled net force while it is chasing a real-time profile movement, without using a force feedback (load cell).

Coupling the actuators with an air bearing system, position feedback device, linear servo amplifier and motion controller yields a system that is capable of handle position, velocity, and acceleration control.

### BENEFITS

**Best force-load ratio**

**Best force output-dimensions ratio**

**No overheating thanks to temperature sensor embedded**

**Top performances thanks to turnkey drives**

### INDUSTRIAL SECTORS

**ELECTRONICS&SEMICONDUCTOR  
PRODUCTION&PACKAGING IN FMCG  
SPECIAL APPLICATIONS**

### APPLICATIONS

**High dynamics contact probes  
Dynamics actuator for heavy duty cycles  
Linear actuator in high dynamics  
High accurate test in force devices**

**MAIN FEATURES**

| MAIN FEATURES                        |          | UM                 | Description |
|--------------------------------------|----------|--------------------|-------------|
| Continuative force                   | $F_N$    | N                  | 100         |
| Peak force                           | $F_p$    | N                  | 300         |
| Force constant                       | $K_F$    | N/A <sub>rms</sub> | 20.9        |
| BEMF constant                        | $K_e$    | V/(m/s)            | 20.9        |
| Electrical resistance <sup>(1)</sup> | R        | $\Omega$           | 2.4         |
| Inductance                           | L        | mH                 | 5.4         |
| Continuous current                   | $I_N$    | A <sub>rms</sub>   | 5           |
| Peak current                         | $I_p$    | APk                | 10          |
| Max continuous power <sup>(2)</sup>  | $P_d$    | W                  | 60          |
| Rated Inverter DC bus Voltage        | $V_{DC}$ | V                  | 60          |
| Stroke                               | $C_m$    | mm                 | 22          |
| Total mass                           | $m_T$    | g                  | 1940        |
| Coil Assembly Mass                   | $m_m$    | g                  | 440         |

| TEMPERATURE SENSOR TE<br>Connectivity 10K3A1iA |  | UM   | Description |
|--|--|------|-------------|
| R @ 25°C                                       |  | Ohms | 10000       |
| 0-70°C Resistance Tolerance                    |  | °C   | ± 0.1       |
| Temperature range                              |  | °C   | up to 125   |
| Time Response                                  |  | s    | <1          |

Performance specs are referred to free air convection cooling

(1) All electric data at 20°C

(2) For best performance: heat transfer coefficient  $\geq 5 \text{ W}/(\text{dm}^2 \cdot \text{K})$  (through coil backside external surface)

| DIMENSIONS            |                         | UM | Description |
|-----------------------|-------------------------|----|-------------|
| External diameter     | $\emptyset \text{ ext}$ | mm | 76          |
| Lenght (mid stroke)   | L                       | mm | 75.2        |
| Lenght                | L1                      | mm | 45.6        |
| Distance (mid stroke) | S                       | mm | 22          |

**OUTLINE DRAWING**

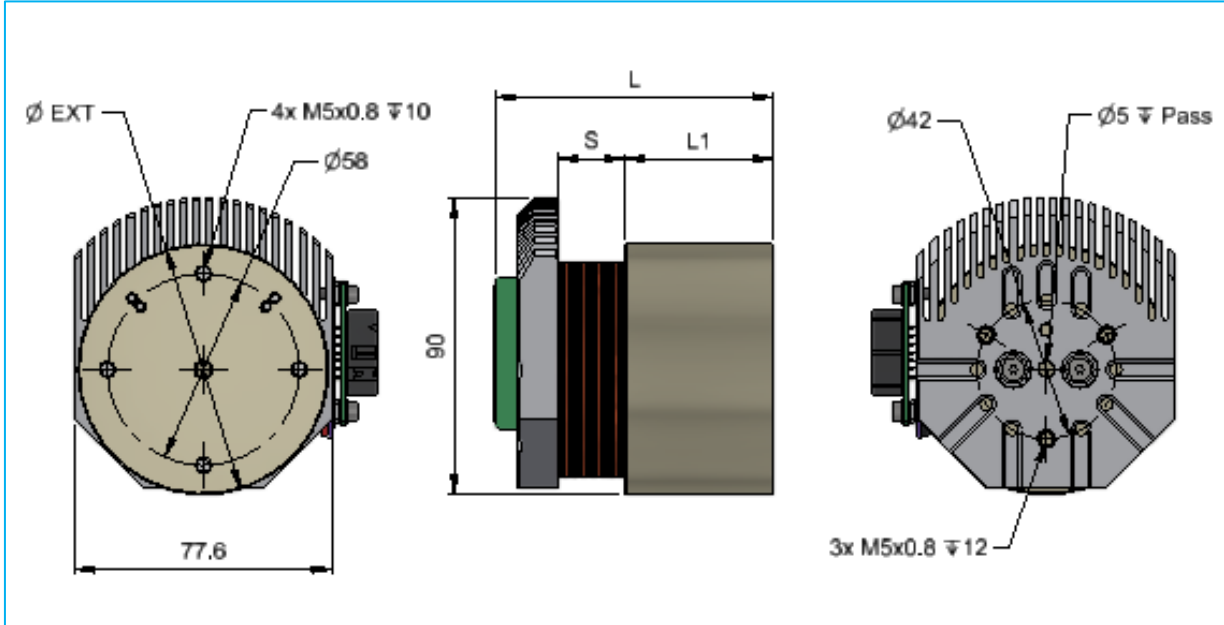

**PERFORMANCES – FORCE VS POSITION**

